

SERIE



MINICILINDRI ISO 6432
ISO 6432 MICRO CYLINDERS



ARTEC[®]
PNEUMATIC COMPONENTS

CARATTERISTICHE TECNICHE - TECHNICAL CHARACTERISTICS

Pressione di esercizio <i>Working pressure</i>	1 ÷ 10 bar
Temperatura di esercizio <i>Working temperature</i>	0 ÷ +80°C (-20°C con aria secca - <i>with dry air</i>) 0 ÷ +150°C (con guarnizioni per alte temperature - <i>with high temperature seals</i>)
Versioni - Versions	semplice effetto, doppio effetto, stelo passante - <i>single acting, double acting, double rod</i>
Alesaggi - Bores	∅ 8 - 10 - 12 - 16 - 20 - 25 (conformi alla norma ISO 6432 - <i>in accordance with ISO 6432</i>) ∅ 32 - 40 - 50 - 63 (non soggetti a normativa - <i>not included in the standard</i>)
Corse - Strokes	vedere tabelle corse standard - <i>see standard stroke tables</i>
Fluido - Fluid	aria compressa filtrata, non lubrificata - <i>compressed filtered, non lubricated air</i>

CARATTERISTICHE COSTRUTTIVE - CONSTRUCTIVE CHARACTERISTICS

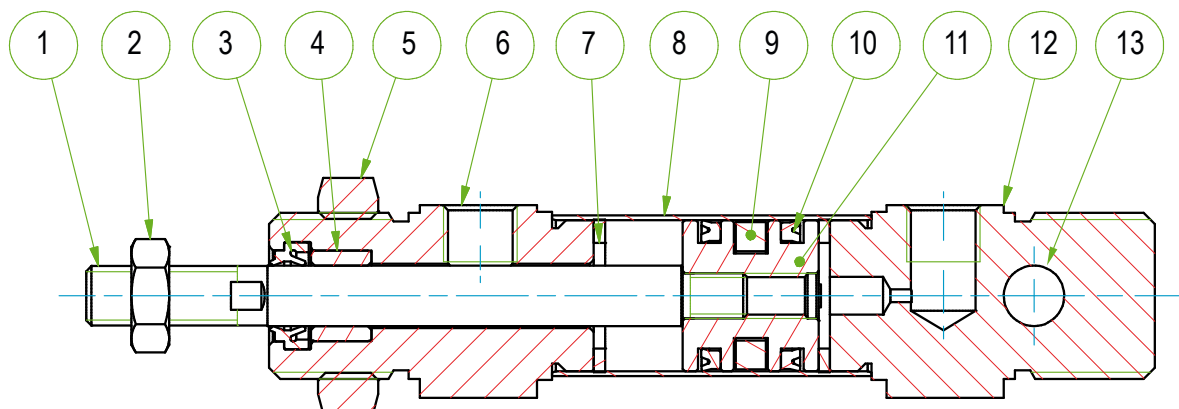
①	Stelo - Rod	∅ 8÷25 acciaio inox AISI 303 - <i>AISI 303 stainless steel</i> ∅ 32÷63 acciaio C45 cromato - <i>C45 Chromed steel</i>
② ⑤	Dado - Nut	acciaio zincato - <i>zinc coated steel</i>
③	Guarnizione stelo - Rod seal	poliuretano - <i>polyurethane</i>
④	Boccola - Bush	bronzo sinterizzato - <i>sintered bronze</i>
⑥ ⑫	Testate - Covers	alluminio anodizzato - <i>anodized aluminium</i>
⑦	Paracolpo - Bumper	neoprene
⑧	Tubo - Tube	acciaio inox AISI 304 - <i>AISI 304 stainless steel</i>
⑩	Guarnizioni pistone - Piston seals	∅ 8÷25 poliuretano - <i>polyurethane</i> ∅ 32÷63 NBR
⑪	Pistone - Piston	ottone - <i>brass</i>
⑨	Magnete - Magnet	plastroferrite - <i>rubber magnet</i>
⑬	Boccola - Bush	∅ 8÷25 non disponibile - <i>not available</i> ∅ 32÷63 acciaio + PTFE - <i>steel + PTFE</i>



CHIAVE DI CODIFICA Ø 8 ÷ 25 (CONFORMI ALLA NORMA ISO 6432)
KEY CODE Ø 8 ÷ 25 (IN ACCORDANCE WITH ISO 6432)
O D M 0 2 5 . 1 0 0 . G S . M

			ALESAGGIO - BORE (Ø) 008-010-012-016 020-025	CORSA - STROKE (mm) vedere tabelle corse std see std stroke tables			OPZIONE - OPTION EX ATEX II 2GD c T4
			VERSIONE - VERSION				OPZIONE - OPTION
		Ø12÷25	P stelo passante double rod				T1 testa corta alimentazione 90° short head connection at 90°
		Ø16÷25	A antirrotazione con stelo esagonale anti-rotation with hexagonal rod				T2 testa corta alimentazione in asse short head connection on axis
			VERSIONE - VERSION				OPZIONE - OPTION
			M magnetico magnetic				W con ammortizzo with cushioning
			non magnetico non-magnetic				OPZIONE - OPTION
			VERSIONE - VERSION				OPZIONE - OPTION
			S semplice effetto molla anteriore single acting front spring				B stelo prolungato per bloccastelo extended rod for rod lock
		Ø16÷25	SE semplice effetto molla posteriore single acting rear spring				B1 stelo prolungato con bloccastelo montato extended rod with rod lock mounted
			D doppio effetto double acting				OPZIONE - OPTION
				GUARNIZIONI - SEALS			X6 stelo in acciaio inox AISI 316 AISI 316 SS rod
				guarnizioni standard standard seals GS			OPZIONE - OPTION
				guarnizione stelo per alte temperature high temperature rod seal VR			STELO - ROD
				tutte le guarnizioni per alte temperature all seals for high temperature VA			M maschio male
SERIE - SERIES							F femmina female
O tubo tondo cianfrinato crimped round tube							FT forato telescopico telescopic hollow rod

ESECUZIONI A RICHIESTA - ON REQUEST

 Filetti speciali (dado non fornito) - *Special thread (without rod nut)*

 Stelo prolungato (WH) - *Extended rod (WH)*

 Corse fuori standard - *Special strokes*
ATEX II 2GD c T4

FORZE TEORICHE DI TRAZIONE (P=6 bar)
THEORETICAL FORCES OF TRACTION (P=6 bar)

		Ø	8	10	12	16	20	25
ODM	SPINTA THRUST	[N]	30	42	60	108	168	264
	TRAZIONE TRACTION	[N]	18	36	45	96	144	216
ODMP	SPINTA THRUST	[N]	18	36	45	96	144	216
	TRAZIONE TRACTION	[N]	18	36	45	96	144	216

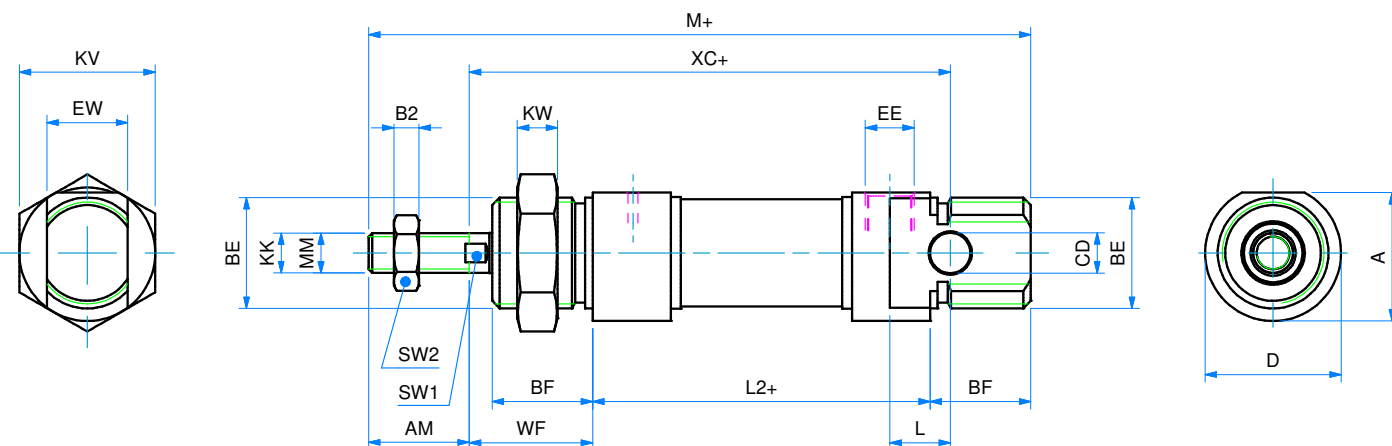
SEMPLICE EFFETTO MAGNETICO - MOLLA ANTERIORE
SINGLE ACTING MAGNETIC - FRONT SPRING

Note: dado stelo compreso nella fornitura
 Note: rod nut included in the supply

DIMENSIONI - DIMENSIONS

ø	8	10	12	16	20	25
A	15	15	18	18	25.5	28.5
AM	12	12	16	16	20	22
B2	4	4	4	4	5	6
BE	M12x1.25	M12x1.25	M16x1.5	M16x1.5	M22x1.5	M22x1.5
BF	12	12	18	18	20	22
CD	4	4	6	6	8	8
ø D	16	16	19	19	27	30
EE	M5	M5	M5	M5	1/8G	1/8G
EW	8	8	12	12	16	16
KK	M4	M4	M6	M6	M8	M10x1.25
KV	19	19	22	22	27	27
KW	7	7	6	6	8	8
L	6	6	9	9	12	12
L2+	46	46	48	53	67	68
M+	86	86	104	109	131	140
ø MM	4	4	6	6	8	10
SW1	-	-	5	5	7	9
SW2	7	7	10	10	13	17
WF	16	16	22	22	24	28
XC+	64	64	75	82	95	104

+ = lunghezza corsa - stroke length

0 CORSE STANDARD - STANDARD STROKES

008 10 - 25 - 50

010 10 - 25 - 50

012 10 - 25 - 50

016 10 - 25 - 50

020 10 - 25 - 50

025 10 - 25 - 50

SEMPLICE EFFETTO MAGNETICO - MOLLA POSTERIORE

 OSEM
 ø 16 ÷ 25

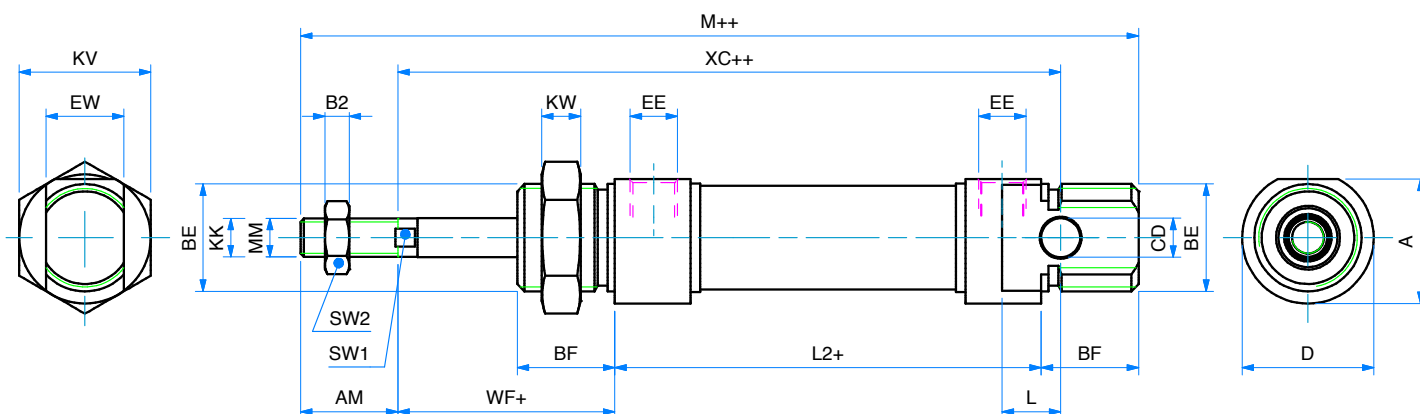
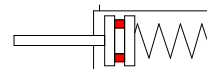
SINGLE ACTING MAGNETIC - REAR SPRING

Note: dado stelo compreso nella fornitura
 Note: rod nut included in the supply

DIMENSIONI - DIMENSIONS

ø	16	20	25
A	18	25,5	28,5
AM	16	20	22
B2	4	5	6
BE	M16x1.5	M22x1.5	M22x1.5
BF	18	20	22
CD	6	8	8
ø D	19	27	30
EE	M5	1/8G	1/8G
EW	12	16	16
KK	M6	M8	M10x1.25
KV	22	27	27
KW	6	8	8
L	9	12	12
L2+	78,5	90	94
M++	134,5	154	166
ø MM	6	8	10
SW1	5	7	9
SW2	10	13	17
WF+	22	24	28
XC++	107,5	118	130

+ = lunghezza corsa - stroke length

++ = 2 x lunghezza corsa - 2 x stroke length

0 CORSE STANDARD - STANDARD STROKES
016 10 - 25 - 50

020 10 - 25 - 50

025 10 - 25 - 50

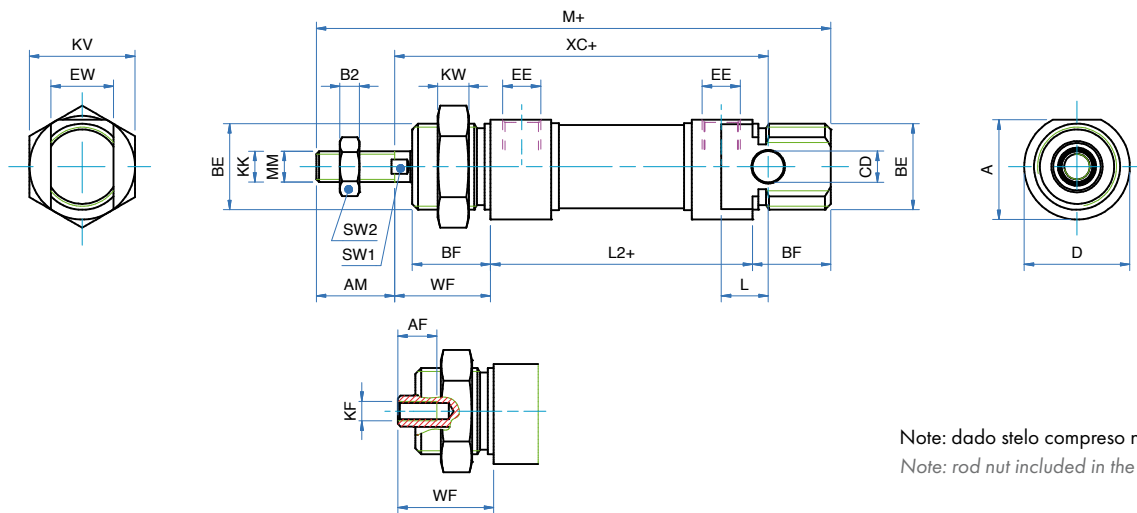
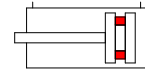
DOPPIO EFFETTO MAGNETICO
DOUBLE ACTING MAGNETIC

Note: dado stelo compreso nella fornitura
 Note: rod nut included in the supply

DIMENSIONI - DIMENSIONS

ø	8	10	12	16	20	25
A	15	15	18	18	25.5	28.5
AF	-	-	-	-	12	12
AM	12	12	16	16	20	22
B2	4	4	4	4	5	6
BE	M12x1.25	M12x1.25	M16x1.5	M16x1.5	M22x1.5	M22x1.5
BF	12	12	18	18	20	22
CD	4	4	6	6	8	8
ø D	16	16	19	19	27	30
EE	M5	M5	M5	M5	1/8G	1/8G
EW	8	8	12	12	16	16
KF	-	-	-	-	M4	M6
KK	M4	M4	M6	M6	M8	M10x1.25
KV	19	19	22	22	27	27
KW	7	7	6	6	8	8
L	6	6	9	9	12	12
L2+	46	46	48	53	67	68
M+	86	86	104	109	131	140
ø MM	4	4	6	6	8	10
SW1	-	-	5	5	7	9
SW2	7	7	10	10	13	17
WF	16	16	22	22	24	28
XC+	64	64	75	82	95	104

ø CORSE STANDARD - STANDARD STROKES
008 10 - 25 - 50 - 80 - 100 - 125

010 10 - 25 - 50 - 80 - 100 - 125

012 10 - 25 - 50 - 80 - 100 - 125 - 160 - 200 - 250 - 320

016 10 - 25 - 50 - 80 - 100 - 125 - 160 - 200 - 250 - 320 - 400 - 500 - 600 - 700 - 800 - 900 - 1000

020 10 - 25 - 50 - 80 - 100 - 125 - 160 - 200 - 250 - 320 - 400 - 500 - 600 - 700 - 800 - 900 - 1000

025 10 - 25 - 50 - 80 - 100 - 125 - 160 - 200 - 250 - 320 - 400 - 500 - 600 - 700 - 800 - 900 - 1000

+ = lunghezza corsa - stroke length

DOPPIO EFFETTO MAGNETICO TESTA CORTA ALIMENTAZIONE 90°

 ODM-T1
 ø 16 ÷ 25

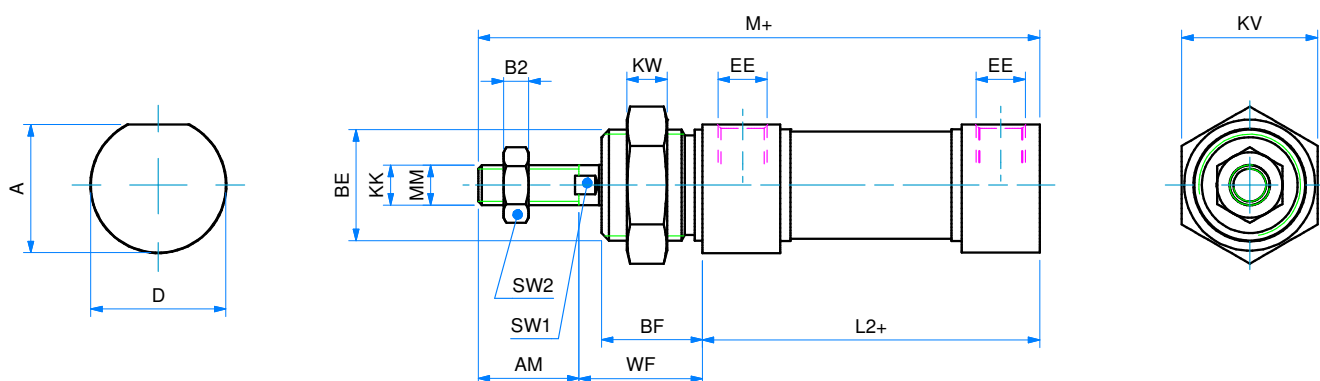
DOUBLE ACTING MAGNETIC SHORT HEAD CONNECTION AT 90°

Note: dado stelo compreso nella fornitura
 Note: rod nut included in the supply

DIMENSIONI - DIMENSIONS

ø	16	20	25
A	18	25,5	28,5
AM	16	20	22
B2	4	5	6
BE	M16x1.5	M22x1.5	M22x1.5
BF	18	20	22
ø D	19	27	30
EE	M5	1/8G	1/8G
KK	M6	M8	M10x1.25
KV	22	27	27
KW	6	8	8
L2+	53	67	68
M+	91	111	118
ø MM	6	8	10
SW1	5	7	9
SW2	10	13	17
WF	22	24	28

+ = lunghezza corsa - stroke length

ø CORSE STANDARD - STANDARD STROKES

016	10 - 25 - 50 - 80 - 100 - 125 - 160 - 200 - 250 - 320 - 400 - 500 - 600 - 700 - 800 - 900 - 1000
020	10 - 25 - 50 - 80 - 100 - 125 - 160 - 200 - 250 - 320 - 400 - 500 - 600 - 700 - 800 - 900 - 1000
025	10 - 25 - 50 - 80 - 100 - 125 - 160 - 200 - 250 - 320 - 400 - 500 - 600 - 700 - 800 - 900 - 1000

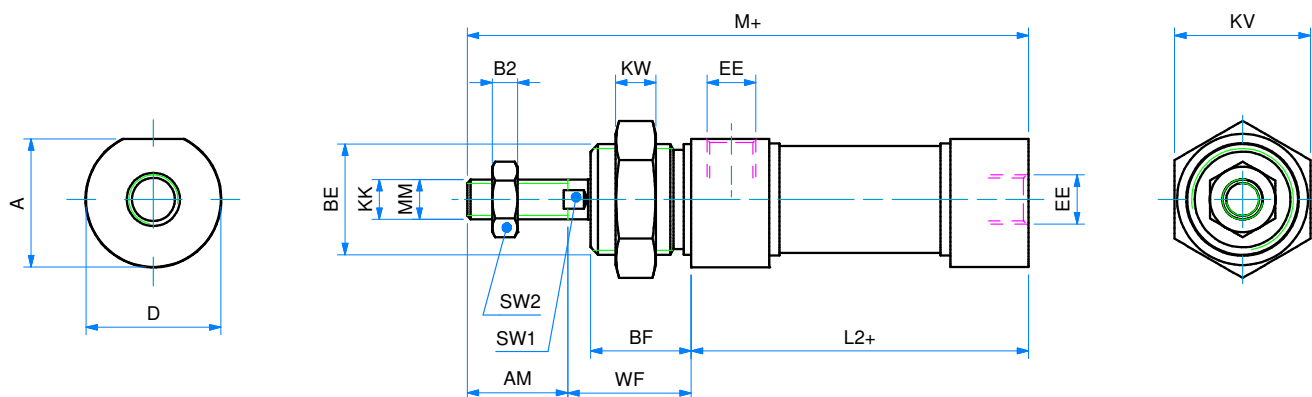
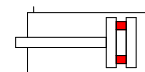
DOPPIO EFFETTO MAGNETICO TESTATA CORTA ALIMENTAZIONE IN ASSE
DOUBLE ACTING MAGNETIC SHORT HEAD CONNECTION ON AXIS

Note: dado stelo compreso nella fornitura
 Note: rod nut included in the supply

DIMENSIONI - DIMENSIONS

ø	16	20	25
A	18	25,5	28,5
AM	16	20	22
B2	4	5	6
BE	M16x1.5	M22x1.5	M22x1.5
BF	18	20	22
ø D	19	27	30
EE	M5	1/8G	1/8G
KV	22	27	27
KW	6	8	8
L2+	53	67	68
M+	91	111	118
ø MM	6	8	10
SW1	5	7	9
SW2	10	13	17
WF	22	24	28

+ = lunghezza corsa - stroke length

ø CORSE STANDARD - STANDARD STROKES

016 10 - 25 - 50 - 80 - 100 - 125 - 160 - 200 - 250 - 320 - 400 - 500 - 600 - 700 - 800 - 900 - 1000

020 10 - 25 - 50 - 80 - 100 - 125 - 160 - 200 - 250 - 320 - 400 - 500 - 600 - 700 - 800 - 900 - 1000

025 10 - 25 - 50 - 80 - 100 - 125 - 160 - 200 - 250 - 320 - 400 - 500 - 600 - 700 - 800 - 900 - 1000

DOPPIO EFFETTO MAGNETICO AMMORTIZZATO

 ODM-W
 ø 16 ÷ 25

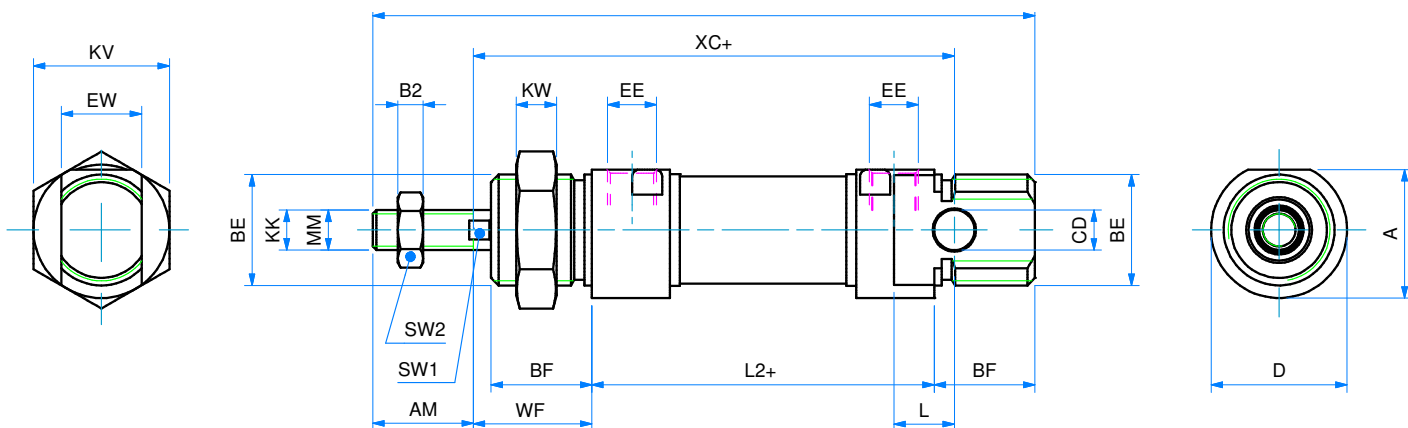
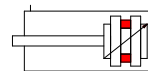
DOUBLE ACTING MAGNETIC CUSHIONED

Note: dado stelo compreso nella fornitura
 Note: rod nut included in the supply

DIMENSIONI - DIMENSIONS

	16	20	25
A	18	25,5	28,5
AM	16	20	22
B2	4	5	6
BE	M16x1.5	M22x1.5	M22x1.5
BF	18	20	22
CD	6	8	8
ø D	21	27	30
EE	M5	1/8G	1/8G
EW	12	16	16
KK	M6	M8	M10x1.25
KV	22	27	27
KW	6	8	8
L	9	12	12
L2+	53	67	68
M+	109	131	140
ø MM	6	8	10
SW1	5	7	9
SW2	10	13	17
WF	22	24	28
XC+	82	95	104

+ = lunghezza corsa - stroke length

ø CORSE STANDARD - STANDARD STROKES
016 10 - 25 - 50 - 80 - 100 - 125 - 160 - 200 - 250 - 320 - 400 - 500 - 600 - 700 - 800 - 900 - 1000

020 10 - 25 - 50 - 80 - 100 - 125 - 160 - 200 - 250 - 320 - 400 - 500 - 600 - 700 - 800 - 900 - 1000

025 10 - 25 - 50 - 80 - 100 - 125 - 160 - 200 - 250 - 320 - 400 - 500 - 600 - 700 - 800 - 900 - 1000

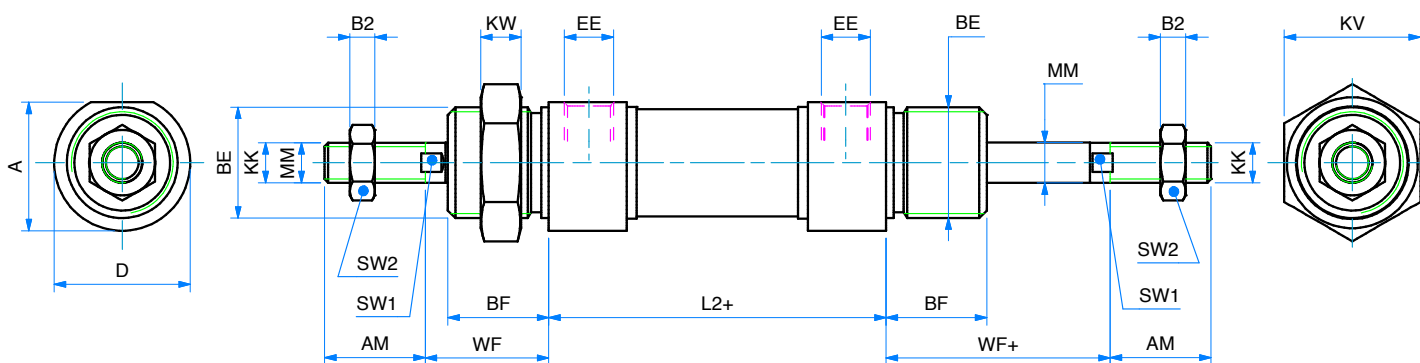
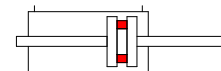
DOPPIO EFFETTO MAGNETICO STELO PASSANTE
DOUBLE ACTING MAGNETIC WITH DOUBLE ROD

Note: dado stelo compreso nella fornitura
 Note: rod nut included in the supply

DIMENSIONI - DIMENSIONS

ø	12	16	20	25
A	18	18	25,5	28,5
AM	16	16	20	22
B2	4	4	5	6
BE	M16x1.5	M16x1.5	M22x1.5	M22x1.5
BF	18	18	20	22
ø D	19	19	27	30
EE	M5	M5	1/8G	1/8G
KK	M6	M6	M8	M10x1.25
KV	22	22	27	27
KW	6	6	8	8
L2+	48	53	67	68
ø MM	6	6	8	10
SW1	5	5	7	9
SW2	10	10	13	17
WF	22	22	24	28
WF+	22	22	24	28

+ = lunghezza corsa - stroke length

ø CORSE STANDARD - STANDARD STROKES

016 10 - 25 - 50 - 80 - 100 - 125 - 160 - 200 - 250 - 320 - 400 - 500 - 600 - 700 - 800 - 900 - 1000

020 10 - 25 - 50 - 80 - 100 - 125 - 160 - 200 - 250 - 320 - 400 - 500 - 600 - 700 - 800 - 900 - 1000

025 10 - 25 - 50 - 80 - 100 - 125 - 160 - 200 - 250 - 320 - 400 - 500 - 600 - 700 - 800 - 900 - 1000

DOPPIO EFFETTO MAGNETICO STELO PASSANTE AMMORTIZZATO

 ODMP-W
 ø 16 ÷ 25

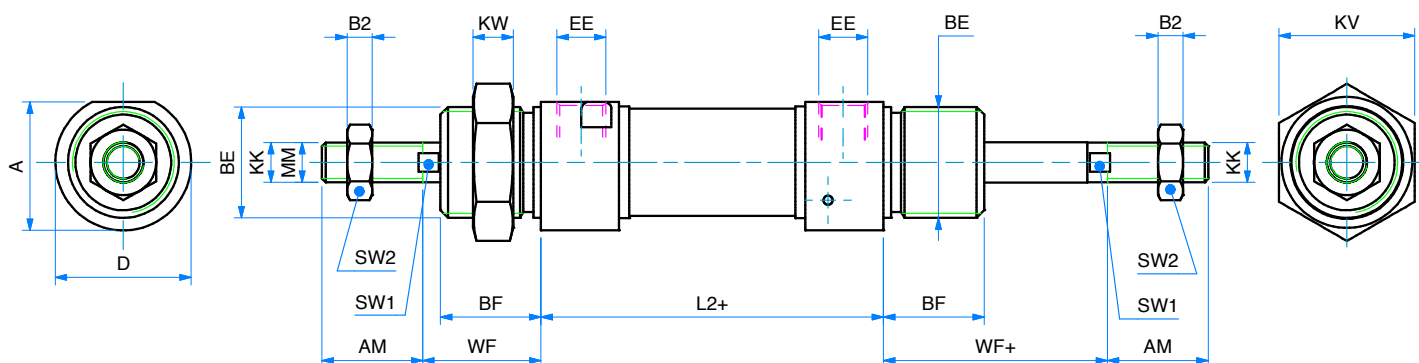
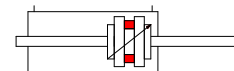
DOUBLE ACTING MAGNETIC CUSHIONED WITH DOUBLE ROD

Note: dado stelo compreso nella fornitura
 Note: rod nut included in the supply

DIMENSIONI - DIMENSIONS

	16	20	25
ø	16	20	25
A	18	25,5	28,5
AM	16	20	22
B2	4	5	6
BE	M16x1.5	M22x1.5	M22x1.5
BF	18	20	22
ø D	21	27	30
EE	M5	1/8G	1/8G
KK	M6	M8	M10x1.25
KV	22	27	27
KW	6	8	8
L2+	53	67	68
ø MM	6	8	10
SW1	5	7	9
SW2	10	13	17
WF	22	24	28
WF+	22	24	28

+ = lunghezza corsa - stroke length

ø CORSE STANDARD - STANDARD STROKES

016 10 - 25 - 50 - 80 - 100 - 125 - 160 - 200 - 250 - 320 - 400 - 500 - 600 - 700 - 800 - 900 - 1000

020 10 - 25 - 50 - 80 - 100 - 125 - 160 - 200 - 250 - 320 - 400 - 500 - 600 - 700 - 800 - 900 - 1000

025 10 - 25 - 50 - 80 - 100 - 125 - 160 - 200 - 250 - 320 - 400 - 500 - 600 - 700 - 800 - 900 - 1000

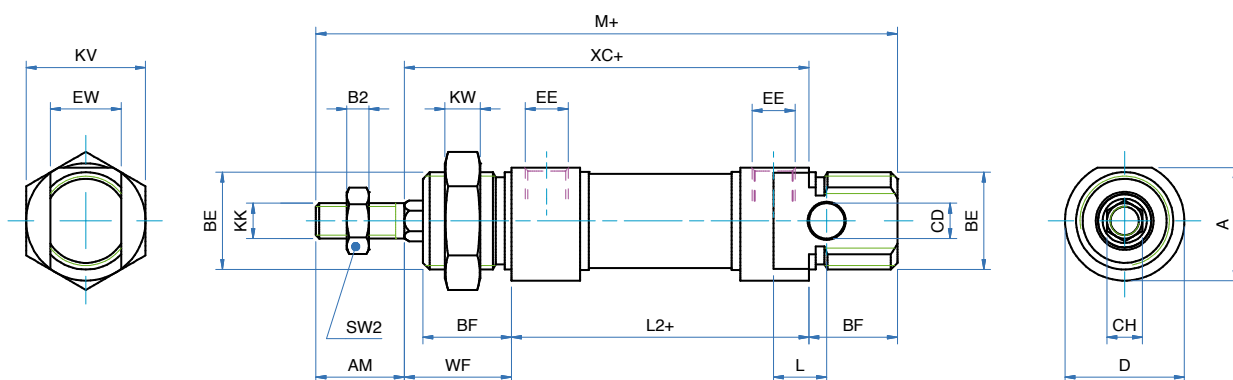
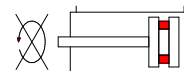
DOPPIO EFFETTO MAGNETICO ANTIROTAZIONE CON STELO ESAGONALE**DOUBLE ACTING MAGNETIC ANTI-ROTATION WITH HEXAGONAL ROD**

Note: dado stelo compreso nella fornitura
Note: rod nut included in the supply

DIMENSIONI - DIMENSIONS

	16	20	25
A	18	25,5	28,5
AM	16	20	22
B2	4	5	6
BE	M16x1,5	M22x1,5	M22x1,5
BF	18	20	22
ø CD	6	8	8
CH	6	8	10
ø D	19	27	30
EE	M5	G 1/8"	G 1/8"
EW	12	16	16
KK	M6	M8	M10x1,25
KV	22	27	27
KW	6	8	8
L	9	12	12
L2+	53	67	68
M+	109	131	140
SW2	10	13	17
WF	22	24	28
XC+	82	95	104

+ = lunghezza corsa - stroke length

ø CORSE STANDARD - STANDARD STROKES

016 10 - 25 - 50 - 80 - 100 - 125 - 160 - 200 - 250 - 320 - 400 - 500 - 600 - 700 - 800 - 900 - 1000

020 10 - 25 - 50 - 80 - 100 - 125 - 160 - 200 - 250 - 320 - 400 - 500 - 600 - 700 - 800 - 900 - 1000

025 10 - 25 - 50 - 80 - 100 - 125 - 160 - 200 - 250 - 320 - 400 - 500 - 600 - 700 - 800 - 900 - 1000

DOPPIO EFFETTO MAGNETICO CON STELO FORATO

 ODM-FT
 ø 25

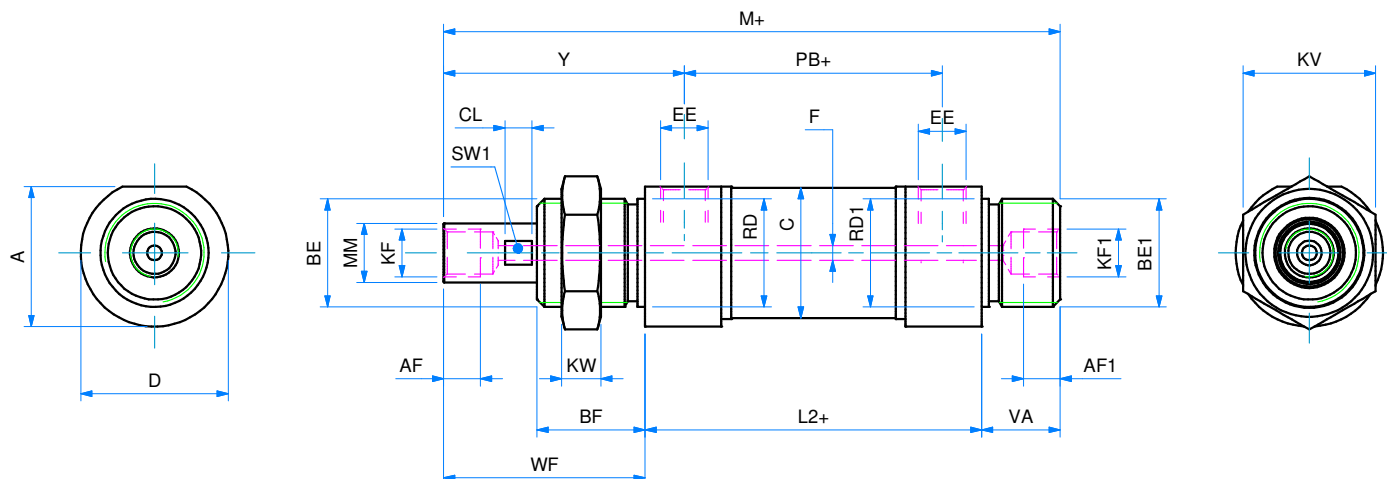
DOUBLE ACTING MAGNETIC WITH HOLLOW ROD

Note: stelo in C45 cromato

Note: C45 chromed rod

DIMENSIONI - DIMENSIONS

ø	25
A	28,5
AF	7,5
AF1	7,5
BE	M22x1,5
BE1	M22x1,5
BF	22
ø C	26,5
CL	5,5
ø D	30
EE	G 1/8"
F	3
KF	G 1/8"
KF1	G 1/8"
KV	27
KW	8
L2+	68
M+	125
ø MM	12
PB+	52
ø RD	22
ø RD1	22
SW1	11
VA	16
WF	41
Y	49

0 CORSE STANDARD - STANDARD STROKES
025 50 - 100 - 150 - 200 - 250 - 300 - 350

+ = lunghezza corsa - stroke length

ACCESSORI DI FISSAGGIO ISO 6432 $\varnothing 8 \div 25$

ISO 6432 MOUNTING PARTS $\varnothing 8 \div 25$

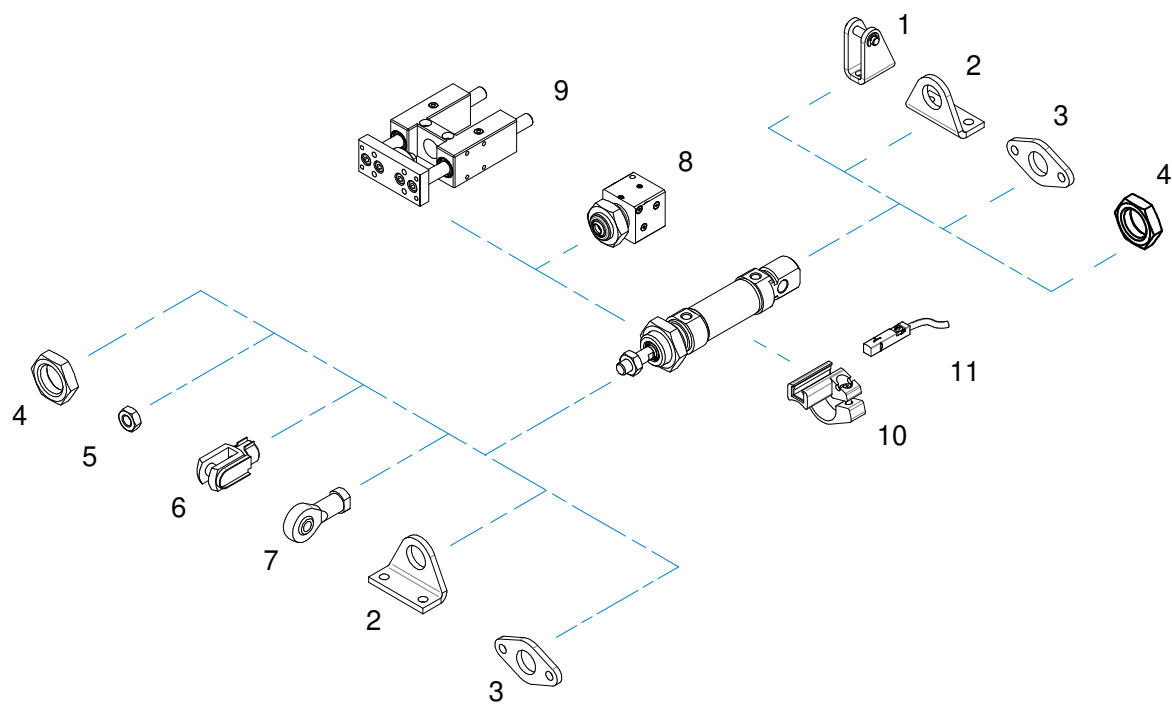

POS.	CODE	DESCRIZIONE - DESCRIPTION
1	MCFI---	cerniera con perno - female hinge with pin
2	MPBI---	pedino - foot mounting
3	MFI---	flangia - flange
4	DAT---	dado testata - nose nut
5	DA--x---	dado stelo - rod nut
6	FC--x---	forcella con clips - clevis with lockable pin
7	SSFI--x---	snodo sferico - rod eye
8	BH---	bloccastelo - rod lock
9	GU---,---.S	unità di guida - guide unit
10	36.TIRM--	adattatore sensore - sensor mounting
11	36-SEN---	sensore magnetico - magnetic sensor

Dimensioni accessori: vedi sezione SERIE W

Accessories dimensions: see SERIE W chapter

CHIAVE DI CODIFICA ø 32 ÷ 63 (NON SOGGETTI A NORMATIVA)
KEY CODE ø 32 ÷ 63 (NOT INCLUDED IN THE STANDARD)

O D M 0 3 2 . 0 5 0 . G S . M

		ALESAGGIO - BORE (ø) 032-040-050-063	CORSA - STROKE (mm) vedere tabelle corse std see std stroke tables		OPZIONE - OPTION W con ammortizzo with cushioning
		VERSIONE - VERSION P stelo passante double rod			OPZIONE - OPTION X4 stelo in acciaio inox AISI 304 cromato chromed AISI 304 SS rod X6 stelo in acciaio inox AISI 316 AISI 316 stainless steel rod
		VERSIONE - VERSION M magnetico magnetic non magnetico non-magnetic		STELO - ROD M maschio male F femmina female	
		VERSIONE - VERSION D doppio effetto double acting		GUARNIZIONI - SEALS GS guarnizioni standard standard seals VR guarnizione stelo per alte temperature high temperature rod seal VA tutte le guarnizioni per alte temperature all seals for high temperature	
SERIE - SERIES		O tubo tondo cianfrinato crimped round tube			

ESECUZIONI A RICHIESTA - ON REQUEST

 Filetti speciali (dado non fornito) - *Special thread (without rod nut)*

 Stelo prolungato (WH) - *Extended rod (WH)*

 Corse fuori standard - *Special strokes*
ATEX II 2GD c T4

FORZE TEORICHE DI TRAZIONE (P=6bar)
THEORETICAL FORCES OF TRACTION (P=6bar)

		ø	32	40	50	63
ODM	SPINTA THRUST	[N]	483	753	1178	1870
	TRAZIONE TRACTION	[N]	415	633	990	1682
ODMP	SPINTA THRUST	[N]	415	633	990	1682
	TRAZIONE TRACTION	[N]	415	633	990	1682

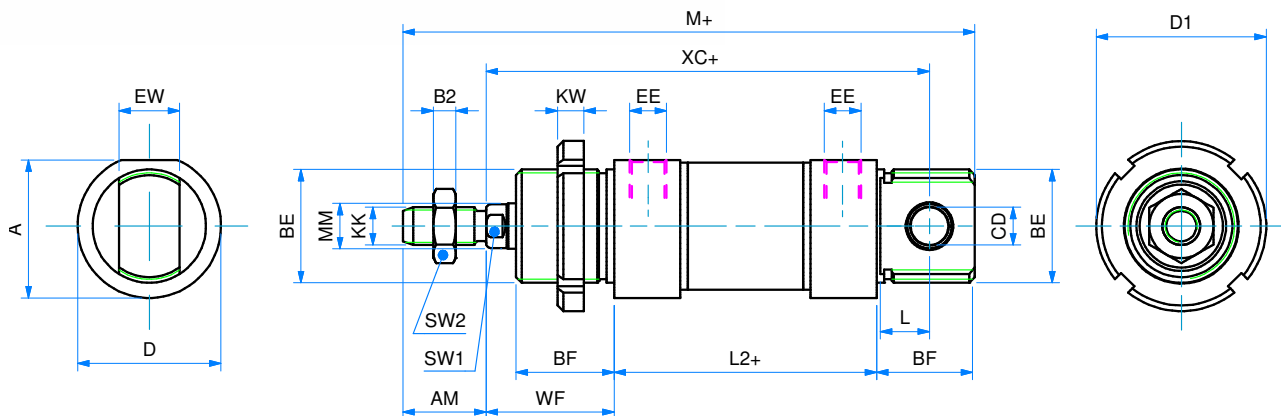
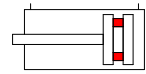
DOPPIO EFFETTO MAGNETICO
DOUBLE ACTING MAGNETIC

Note: dado stelo e ghiera compresi nella fornitura
 Note: rod nut and slotted nut included in the supply

DIMENSIONI - DIMENSIONS

ø	32	40	50	63
A	36,5	44	55	67,5
AM	22	24	32	32
B2	6	7	8	8
BE	M30x1,5	M38x1,5	M45x1,5	M45x1,5
BF	26	30	33	33
ø CD E10	10	12	16	16
ø D	38	46	57	70
ø D1	45	50	58	58
EE	G1/8	G1/4	G1/4	G3/8
EW	16	18	21	21
KK	M10x1,25	M12x1,25	M16x1,5	M16x1,5
KW	7	8	9	9
L	13	15	16	16
L2+	69,5	84,6	86,2	94,2
M+	151,5	177,6	195,2	204,2
ø MM	12	16	20	20
SW1	10	13	17	17
SW2	17	19	24	24
WF	34	39	44	45
XC ±1	117,5	139,6	147,2	156,2

+ = lunghezza corsa - stroke length

ø CORSE STANDARD - STANDARD STROKES

032	25 - 50 - 80 - 100 - 125 - 160 - 200 - 250 - 320 - 400 - 500 - 600 - 700 - 800 - 900 - 1000
040	25 - 50 - 80 - 100 - 125 - 160 - 200 - 250 - 320 - 400 - 500 - 600 - 700 - 800 - 900 - 1000
050	25 - 50 - 80 - 100 - 125 - 160 - 200 - 250 - 320 - 400 - 500 - 600 - 700 - 800 - 900 - 1000
063	25 - 50 - 80 - 100 - 125 - 160 - 200 - 250 - 320 - 400 - 500 - 600 - 700 - 800 - 900 - 1000

 ODM-W
 ø 32 ÷ 63

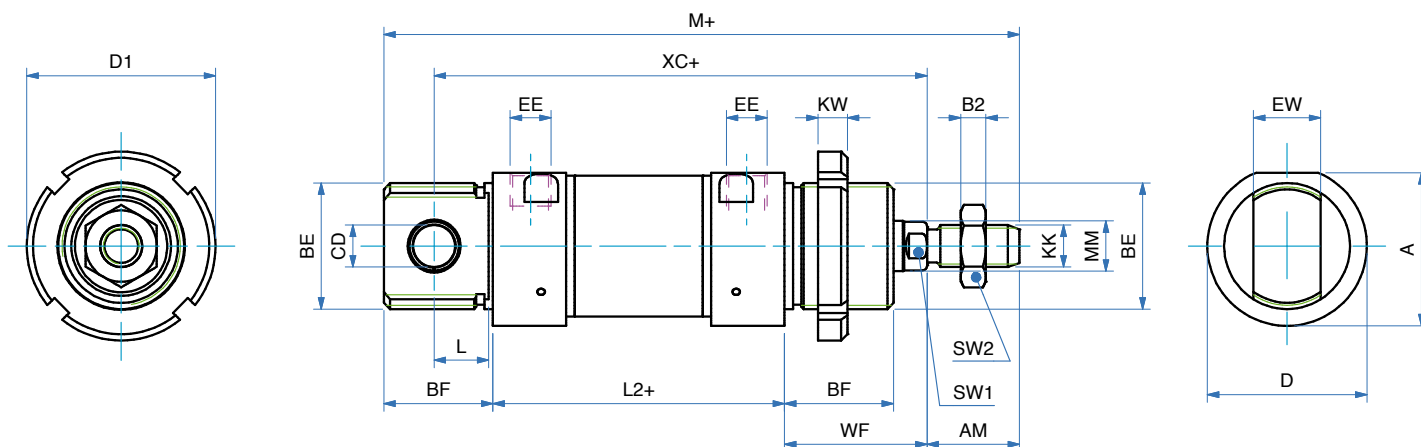
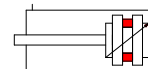
DOPPIO EFFETTO MAGNETICO AMMORTIZZATO
DOUBLE ACTING MAGNETIC CUSHIONED

Note: dado stelo e ghiera compresi nella fornitura

Note: rod nut and slotted nut included in the supply

DIMENSIONI - DIMENSIONS

	32	40	50	63
A	36,5	44	55	67,5
AM	22	24	32	32
B2	6	7	8	8
BE	M30x1,5	M38x1,5	M45x1,5	M45x1,5
BF	26	30	33	33
ø CD E10	10	12	16	16
ØD	38	46	57	70
ø D1	45	50	58	58
EE	G1/8	G1/4	G1/4	G3/8
EW	16	18	21	21
KK	M10x1,25	M12x1,25	M16x1,5	M16x1,5
KW	7	8	9	9
L	13	15	16	16
L2+	69,5	84,6	86,2	94,2
M+	151,5	177,6	195,2	204,2
ø MM	12	16	20	20
SW1	10	13	17	17
SW2	17	19	24	24
WF	34	39	44	45
XC ±1	117,5	139,6	147,2	156,2

+ = lunghezza corsa - stroke length

0 CORSE STANDARD - STANDARD STROKES

032	25 - 50 - 80 - 100 - 125 - 160 - 200 - 250 - 320 - 400 - 500 - 600 - 700 - 800 - 900 - 1000
040	25 - 50 - 80 - 100 - 125 - 160 - 200 - 250 - 320 - 400 - 500 - 600 - 700 - 800 - 900 - 1000
050	25 - 50 - 80 - 100 - 125 - 160 - 200 - 250 - 320 - 400 - 500 - 600 - 700 - 800 - 900 - 1000
063	25 - 50 - 80 - 100 - 125 - 160 - 200 - 250 - 320 - 400 - 500 - 600 - 700 - 800 - 900 - 1000

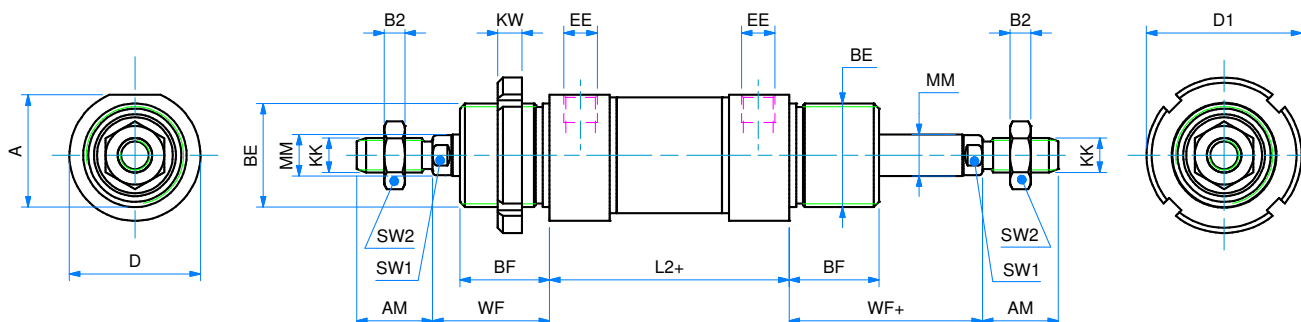
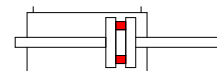
DOPPIO EFFETTO MAGNETICO STELO PASSANTE
DOUBLE ACTING MAGNETIC WITH DOUBLE ROD

Note: dado stelo e ghiera compresi nella fornitura
 Note: rod nut and slotted nut included in the supply

DIMENSIONI - DIMENSIONS

ø	32	40	50	63
A	36,5	44	55	67,5
AM	22	24	32	32
B2	6	7	8	8
BE	M30x1,5	M38x1,5	M45x1,5	M45x1,5
BF	26	30	33	33
ø D	38	46	57	70
ø D1	45	50	58	58
EE	G1/8	G1/4	G1/4	G3/8
KK	M10x1,25	M12x1,25	M16x1,5	M16x1,5
KW	7	8	9	9
L2+	69,5	84,6	86,2	94,2
ø MM	12	16	20	20
SW1	10	13	17	17
SW2	17	19	24	24
WF	34	39	44	45
WF+	34	39	44	45

+ = lunghezza corsa - stroke length

ø CORSE STANDARD - STANDARD STROKES

032	25 - 50 - 80 - 100 - 125 - 160 - 200 - 250 - 320 - 400 - 500 - 600 - 700 - 800 - 900 - 1000
040	25 - 50 - 80 - 100 - 125 - 160 - 200 - 250 - 320 - 400 - 500 - 600 - 700 - 800 - 900 - 1000
050	25 - 50 - 80 - 100 - 125 - 160 - 200 - 250 - 320 - 400 - 500 - 600 - 700 - 800 - 900 - 1000
063	25 - 50 - 80 - 100 - 125 - 160 - 200 - 250 - 320 - 400 - 500 - 600 - 700 - 800 - 900 - 1000

DOPPIO EFFETTO MAGNETICO STELO PASSANTE AMMORTIZZATO

 ODMP-W
 ø 32 ÷ 63

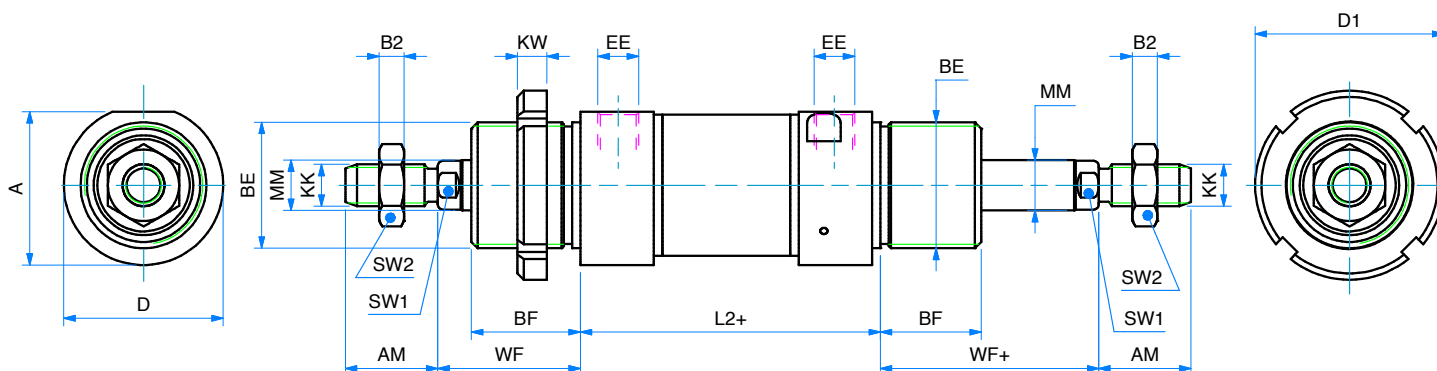
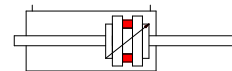
DOUBLE ACTING MAGNETIC CUSHIONED WITH DOUBLE ROD

Note: dado stelo e ghiera compresi nella fornitura
 Note: rod nut and slotted nut included in the supply

DIMENSIONI - DIMENSIONS

ø	32	40	50	63
A	36,5	44	55	67,5
AM	22	24	32	32
B2	6	7	8	8
BE	M30x1,5	M38x1,5	M45x1,5	M45x1,5
BF	26	30	33	33
ø D	38	46	57	70
ø D1	45	50	58	58
EE	G1/8	G1/4	G1/4	G3/8
KK	M10x1,25	M12x1,25	M16x1,5	M16x1,5
KW	7	8	9	9
L2+	69,5	84,6	86,2	94,2
ø MM	12	16	20	20
SW1	10	13	17	17
SW2	17	19	24	24
WF	34	39	44	45
WF+	34	39	44	45

+ = lunghezza corsa - stroke length

ø CORSE STANDARD - STANDARD STROKES

032	25 - 50 - 80 - 100 - 125 - 160 - 200 - 250 - 320 - 400 - 500 - 600 - 700 - 800 - 900 - 1000
040	25 - 50 - 80 - 100 - 125 - 160 - 200 - 250 - 320 - 400 - 500 - 600 - 700 - 800 - 900 - 1000
050	25 - 50 - 80 - 100 - 125 - 160 - 200 - 250 - 320 - 400 - 500 - 600 - 700 - 800 - 900 - 1000
063	25 - 50 - 80 - 100 - 125 - 160 - 200 - 250 - 320 - 400 - 500 - 600 - 700 - 800 - 900 - 1000

ACCESSORI DI FISSAGGIO CILINDRO TONDO Ø 32 ÷ 63

ROUND CYLINDER MOUNTING PARTS Ø 32 ÷ 63

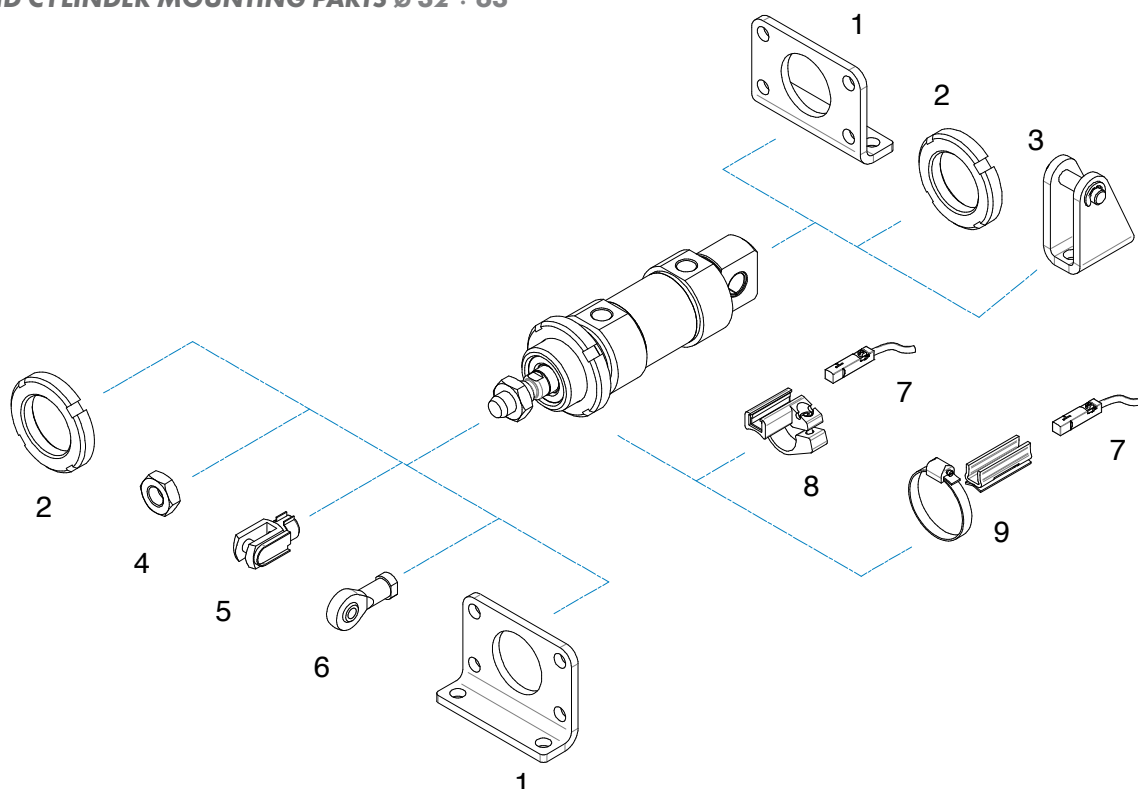

POS.	CODE	DESCRIZIONE - DESCRIPTION
1	MPBI---	pedino flangia - foot flange
2	GHI---	ghiera - slotted nut
3	MCFO---	cerniera femmina con perno (solo Ø 32-40) - female hinge with pin (only Ø 32-40)
4	DA--x---	dado stelo - rod nut
5	FC--x---	forcella con clips - clevis with lockable pin
6	SSFI--x---	snodo sferico - rod eye
7	36.SEN---	sensore magnetico - magnetic sensor
8	36.TIRM--	adattatore sensore - sensor mounting
9	36.TIRX--	adattatore sensore - sensor mounting

Dimensioni accessori: vedi sezione SERIE W

Accessories dimensions: see SERIE W chapter